

scia systems



FULL SURFACE ETCHING

scia Mill 150

Features & Benefits

- Etching angle adjustment with tiltable and rotatable substrate holder
- Excellent uniformity without shaper
- Enhanced selectivity and rate with reactive gases
- Process control with exact SIMS based or optical end point detection
- Carrier concept for adaptation to variable substrate sizes
- Processing of wafers with photoresist masks due to good wafer cooling

Applications

- Structuring of magnetic memory (MRAM) and sensors (GMR, TMR)
- Milling of metals in MEMS production (Au, Ru, Ta, ...)
- Milling of multilayers of different metal and dielectric materials
- CAIBE of compound semiconductors (GaAs, GaN, InP, ...)
- Production of 3-dimensional optoelectronic microstructures
- Ion beam smoothing for reduction of microroughness
- RIBE for pattern transfer for optical gratings (SiO₂)

Principle

- Ion Beam Etching (IBE) / Ion Beam Milling (IBM), Reactive Ion Beam Etching (RIE), Chemically Assisted Ion Beam Etching (CAIBE)
 - Circular ion beam source etches full substrate area under a defined angle with inert or reactive gases

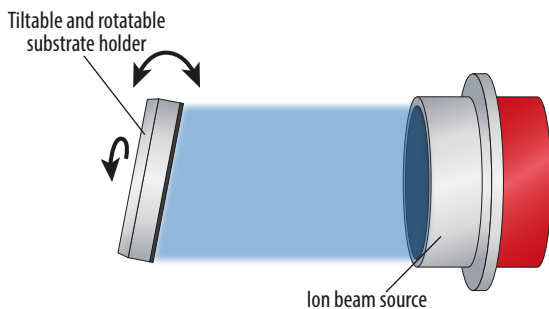

Application Example

- Etching of 15 μm lithium tantalate with photoresist and 15° angle of incidence for a pyroelectric sensor
 - Left: Standard photoresist mask with sharp edges
 - Right: Optimized photoresist with smooth edges improves electrical bonding of the sensor

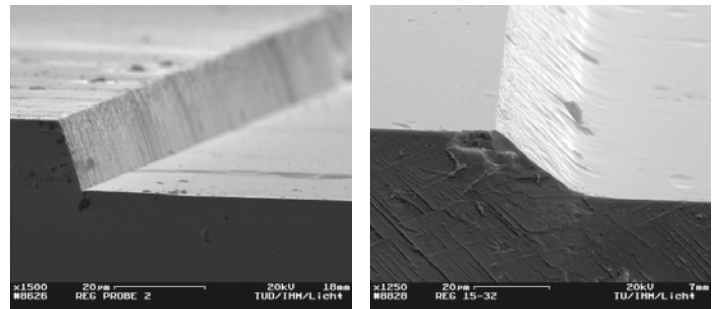

SEM pictures of etching edge with courtesy of DIAS Infrared GmbH

Technical Data

Substrate size (up to)	150 mm dia.
Substrate holder	Water-cooled, helium backside cooling contact, substrate rotation 1 to 20 rpm, tiltable in-situ from 0° to 165° in 0.1° steps
Ion beam source	190 mm circular microwave ECR source (MW218-e)
Neutralizer	Triple plasma bridge neutralizer (N-3DC) RF plasma bridge neutralizer (RF-PBN)
Typical removal rates	SiO ₂ : 20 nm/min (inert), SiO ₂ : 40 - 60 nm/min (reactive)
Uniformity variation	≤ 3 % (σ/mean)
Base pressure	< 5 x 10 ⁻⁷ mbar
System dimension (W x D x H)	1.90 m x 1.80 m x 1.75 m (without electrical rack)
Configurations	Single chamber, optional single substrate load lock, optional OES or SIMS based end point detection
Software interfaces	SECS II / GEM, OPC

