

Scanning MEMS Mirror – 0.6, 1.5, 2.0 mm Diameter

(Single and Dual-Axis, Up To 7 Degree, High Precision, High Repeatability)



The SMEM series of scanning two axis (tip-tilt) and one axis tilt MEMS mirror provide 2D and 1D optical beam-steering functions. The SMEMS features faster scanning, very low power consumption, high precision, and high repeatability. The MEMS is made of single-crystal silicon with flat and smooth mirror coated with a highly refractive gold thin film. The SMEM is hermetically packaged with an optical window designed for 25 years continuously operation. Driving PCB is also offered for convenient evaluations. For volume application contact sales

Features

- Compact
- High Reliability
- Low Power Consumption
- High Repeatability

Specifications

Parameter	Min	Typical	Max	Unit	
Mirror Diameter	0.6	1.5	2	mm	
Operation Wavelength	450		2600	nm	
Reflectivity (@1260-1660nm)	95		96	%	
Tilt Angle	0.6mm@60V	± 2.2	± 2.5	± 2.7	degree
	1.5mm@67V	± 6.8	± 7	± 7.6	
	2.0mm@200V	± 5.9	± 6	± 6.2	
Damage Voltage	0.6mm		70	V	
	1.5mm		70		
	2mm X-axis		220		
	2mm Y-axis		100		
Resonance Frequency	0.6mm	600		Hz	
	1.5mm	750			
	2mm X-axis	500			
	2mm Y-axis	1000			
Response Time		5	10	ms	
Optical Power Handling		500		mW	
Durability	10 ¹⁰			Cycle	
Device Resistance	2			MOhm	
Power Consumption			0.5	mW	
Operating Temperature	-40		75	°C	
Storage Temperature	-40		85	°C	
Reliability	Telcordia 1209 and 1221				
Package Leak Rate	<10 ⁻⁹			Pa.m ³ /s	

Applications

- Optical Devices
- Sensors
- Instrumentation

Note: The specifications provided are for general applications with a cost-effective approach. If you need to narrow or expand the tolerance, coverage, limit, or qualifications, please [click this link](#):

Legal notices: All product information is believed to be accurate and is subject to change without notice. Information contained herein shall legally bind Agiltron only if it is specifically incorporated into the terms and conditions of a sales agreement. Some specific combinations of options may not be available. The user assumes all risks and liability whatsoever in connection with the use of a product or its application.

Rev 12/20/24

Scanning MEMS Mirror – 0.6, 1.5, 2.0 mm Diameter

(Single and Dual-Axis, Up To 7 Degree, High Precision, High Repeatability)



DATASHEET

Mechanical Footprint Dimensions (mm)

■ 2D 0.6mm

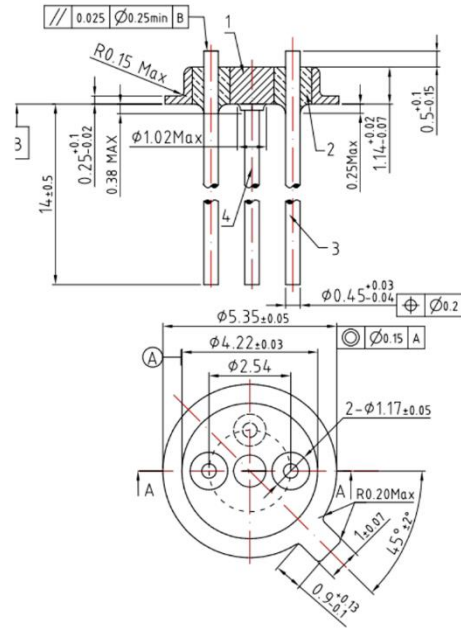
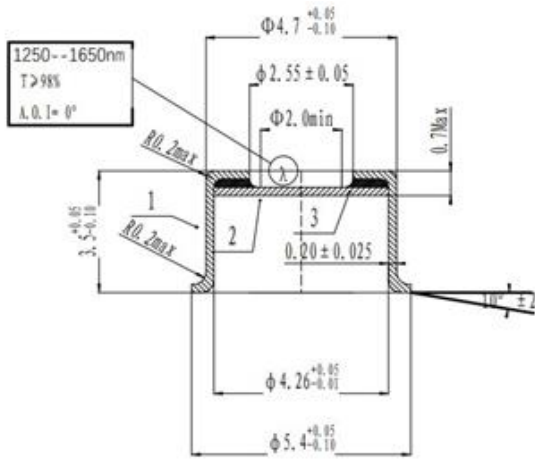

■ 1D 1.5mm

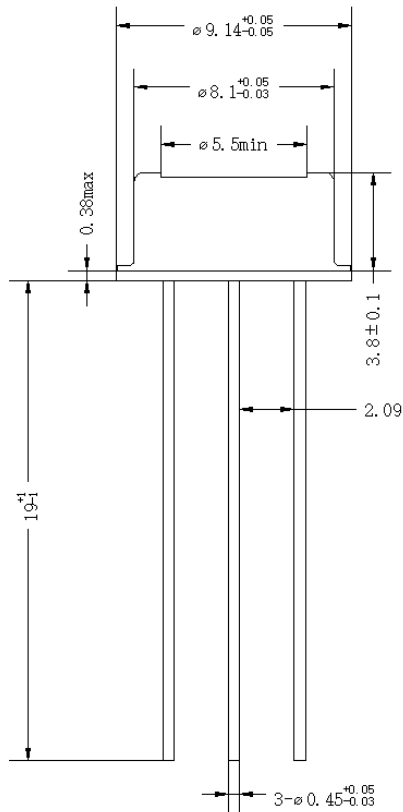

*Product dimensions may change without notice. This is sometimes required for non-standard specifications.

Scanning MEMS Mirror – 0.6, 1.5, 2.0 mm Diameter

(Single and Dual-Axis, Up To 7 Degree, High Precision, High Repeatability)



DATASHEET

MEMS Structure (2D 0.6mm Diameter Mirror)

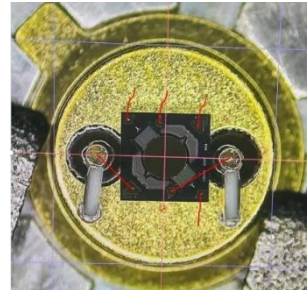
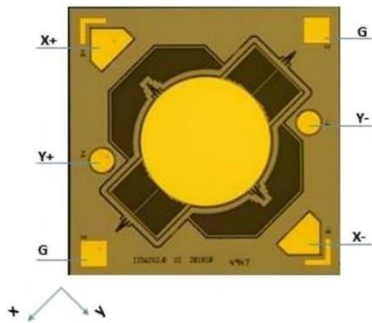

Rotation	DC +	DC -
X+	Pad X+	Pads G, X-,Y+,Y-
X-	Pad X-	Pads G, X+,Y+,Y-
Y+	Pad Y+	Pads G, X+,X-,Y-
Y-	Pad Y-	Pads G, X+,X-,Y+

Note:

- The pins coated with 0.4μm thick Gold

MEMS Structure (1D 1.5mm Diameter Mirror)

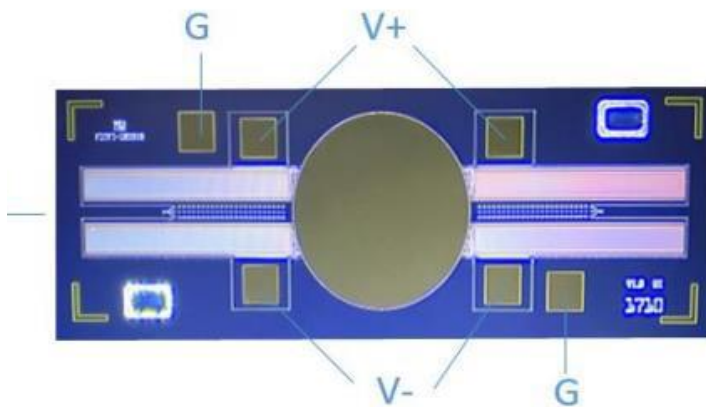

Rotation	DC +	DC -
X+	Pad V+	Pads G, Pad V-
X-	Pad V-	Pads G, Pad V+

Note:

- The pins coated with 0.4μm thick Gold

Scanning MEMS Mirror – 0.6, 1.5, 2.0 mm Diameter

(Single and Dual-Axis, Up To 7 Degree, High Precision, High Repeatability)



DATASHEET

MEMS Structure (2D, 2mm Diameter Mirror)

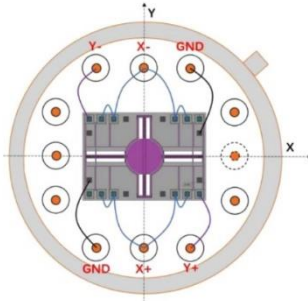

Electronic Driving Instruction

Rotation	DC	GND
X+	Pad X+	
X-	Pad X-	
Y+	Pad Y+	
Y-	Pad Y-	

Note:

- The pins coated with 0.4µm thick Gold

Ordering Information

Prefix	Mirror Size	Window Coating	Axis	Surface	Chip Package	Tilting Angle °	USB Electric Driver	
SMEM-	∅0.8mm = 8	1230-1650nm = 1 Special = 0	2D = 2	Gold = 1	TOCAN = 1 Bare Chip = 2	X±2.2: Y± 2.7= 23	None = 1 Yes = 2	1
SMEM-	∅1mm = 1	1230-1650nm = 1 Special = 0	2D = 2	Gold = 1	TOCAN = 1 Bare Chip = 2	± 3 = 03 X± 2: Y± 4= 24	None = 1 Yes = 2	1
SMEM-	∅1.5mm = 5	1230-1650nm = 1 Special = 0	2D = 2	Gold = 1	TOCAN = 1 Bare Chip = 2	± 10 = 10	None = 1 Yes = 2	1
SMEM-	∅2mm = 2	1230-1650nm = 1 Special = 0	2D = 2	Gold = 1	TOCAN = 1 Bare Chip = 2	X±6: Y± 15= 65	None = 1 Yes = 2	1

Red for special order

Information contained herein is deemed to be reliable and accurate as of the issue date. Photonwares reserves the right to change the design or specifications at any time without notice. Agiltron is a registered trademark of Photonwares Corporation in the U.S. and other countries.

Scanning MEMS Mirror – 0.6, 1.5, 2.0 mm Diameter

(Single and Dual-Axis, Up To 7 Degree, High Precision, High Repeatability)



DATASHEET

Tilting Performance (Typical)

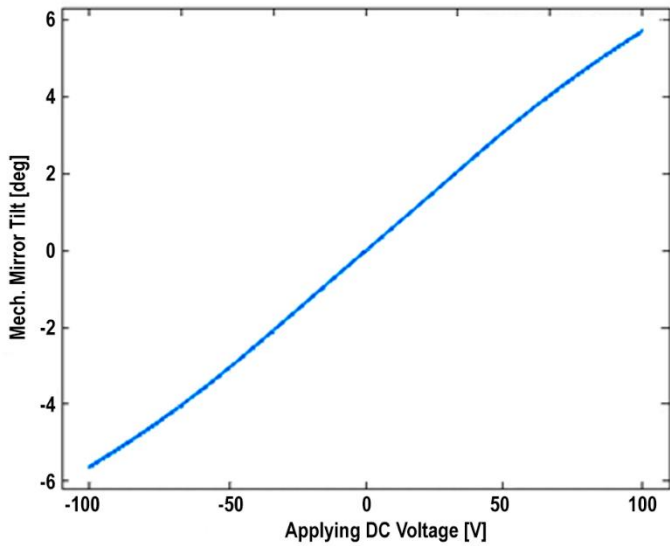

Frequency Response (Typical)

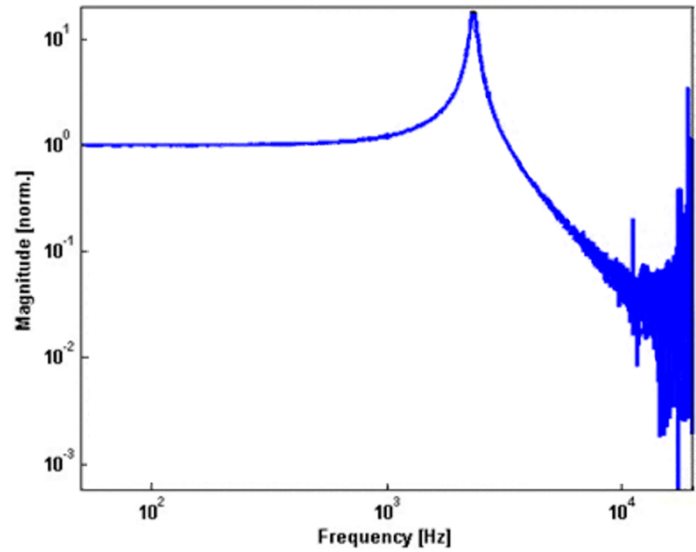

XYZ	Chip Size (mm)	Mirror Diameter (μm)	Rotating Angle	Drive Voltage
X-, X+, Y-, Y+	Typical: 1.7 x 1.7 x 0.61	800	2.2 ~ 2.7 °	< 60
X-, X+	MIN: 5.48 x 1.88 x 0.55 Typical: 5.5 x 1.9 x 0.575 MAX: 5.52 x 1.92 x 0.6	1500	7.5 °	< 70
X-, X+	Typical: 5.5 x 1.9 x 0.62	1500	±10 °	< 110
X-, X+, Y-, Y+	Typical: 7 x 5 x 0.8	2000	X: ±6 ° Y: ±15 °	X < 220 Y < 100
X-, X+, Y-, Y+	Typical: 1.7 x 1.7 x 0.61	800	2.2 ~ 2.7 °	< 60
X-, X+, Y-, Y+	Typical: 1.8 x 1.8 x 0.61	1000	±3.0 °	< 60
X-, X+	Typical: 1.0 x 1.0 x 0.57	595	0.23 ~ 0.33 °	< 6
X+	Typical: 1.7 x 1.7 x 0.57	860	0.28 ° @5V	< 8
X-, X+, Y-, Y+	Typical: 1.9 x 3.2 x 0.62	1000	X: ±2 ° Y: ±4 °	< 60