

SuperLight Photonics

Better Light | More Insight

Carla Camp 2024

25 November 2024

Bradley Snyder - COO



SUPERLIGHT PHOTONICS IN A NUTSHELL

- A **fabless semiconductor** company for Photonic Integrated Circuits (PICs)
- Specialized in **supercontinuum generation** technology
 - Used for Wideband Lasers, Ultra-Fast Lasers, and Optical Frequency Combs (OFCs)
- Focusing on OCT (Optical Coherence Tomography)
 - For ISM (**Industrial, Scientific, and Medical**) applications
 - Additional opportunities
 - Metrology, spectroscopy, microscopy
 - Long term in datacom, photonic/quantum computing, and holographic display

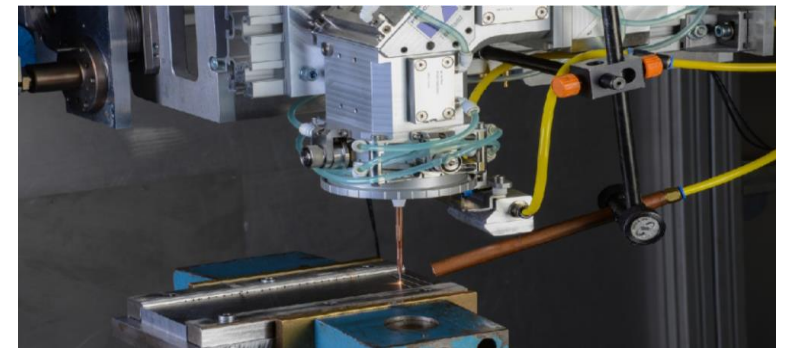
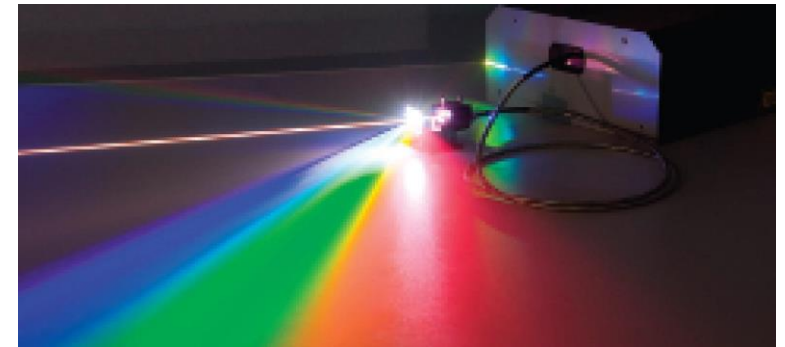
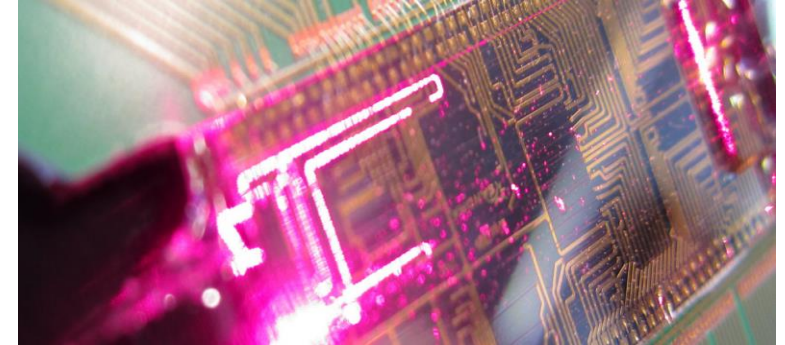

PARADIGM SHIFT IN LASERS

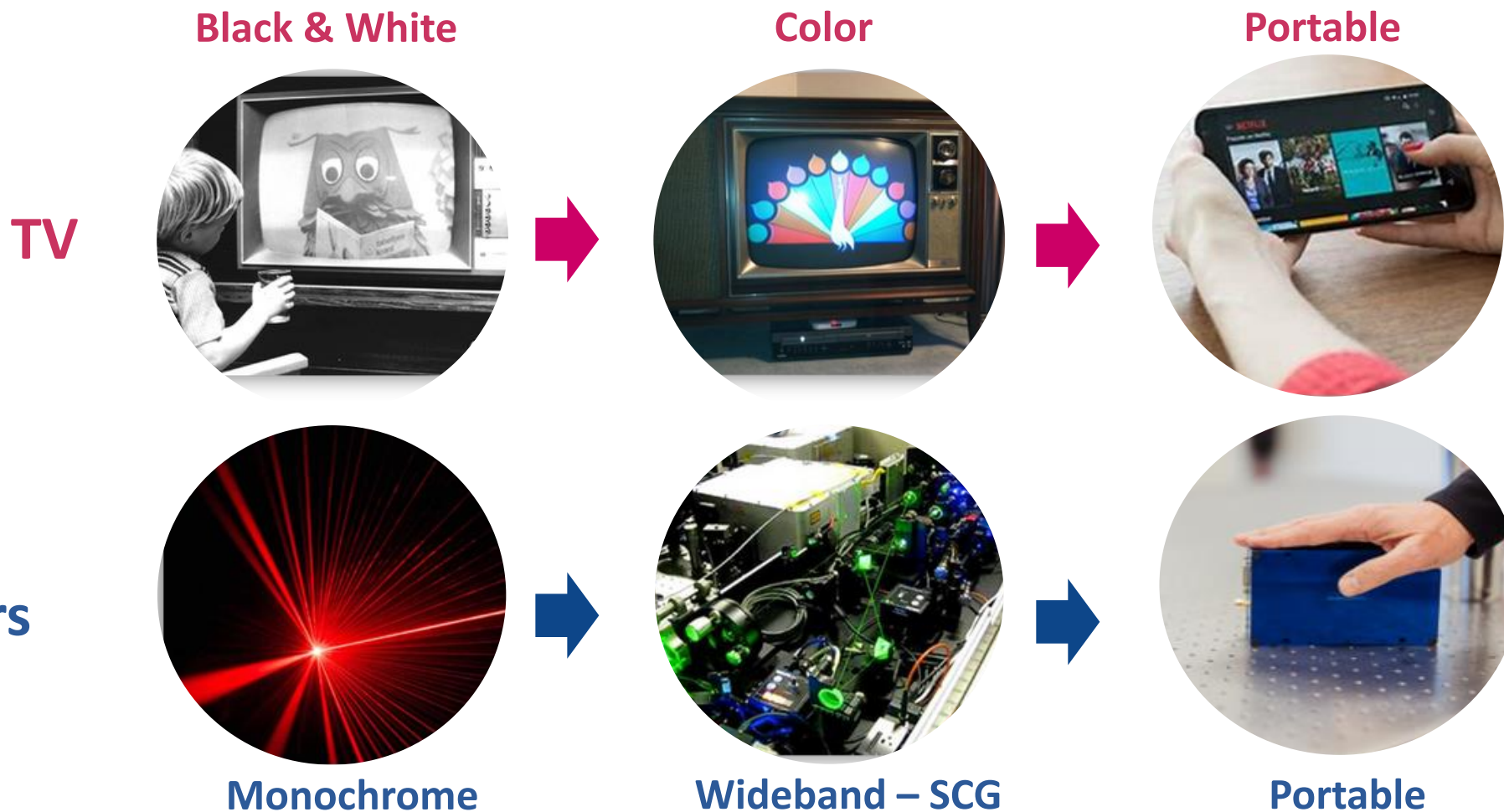

TOO GOOD TO BE TRUE



Current Pain Points

- Traditional lasers provide **monochromatic** light
- **Wideband light** sources (halogen, SLED) are **not very coherent** and **not power-efficient**
- **Wideband lasers** are cumbersome:
 - Bulky, large and heavy
 - Consume a lot of power
 - Deliver low spectral quality (noisy)
 - Long start-up time, sensitive to vibration
 - Require frequent maintenance/recalibration
 - Expensive



Our Solution

- ✓ **Superior PIC-based coherent wideband lasers, portable, low-energy, ultra-low noise and low maintenance**
 - 🌿 Record, coherent wide bandwidth (1000+ nm)
 - ★★★ Ultra-low noise (200 times or more better)
 - ⚡ High quality, smooth spectral output
 - 🔋 Energy efficient – battery operated
 - 🛠️ Small size, low weight, portable & robust
 - 🏆 Short start-up time, low maintenance
- ✓ **Based on PAD - Patterned Alternating Dispersion™ patented technology**

Vision
Mission
Goal
Values

Vision



Ultra-wideband lasers will become the dominant light source for information-based applications

Mission



To make the world's best compact and energy efficient ultra-wideband lasers

Goal



To create a sustainably growing business in PIC-based photonics achieving 10% market share in 2030 (€40M) and further build from there

Values



Committed to excellence, innovation, sustainability, and teamwork

THE FIRST YEAR

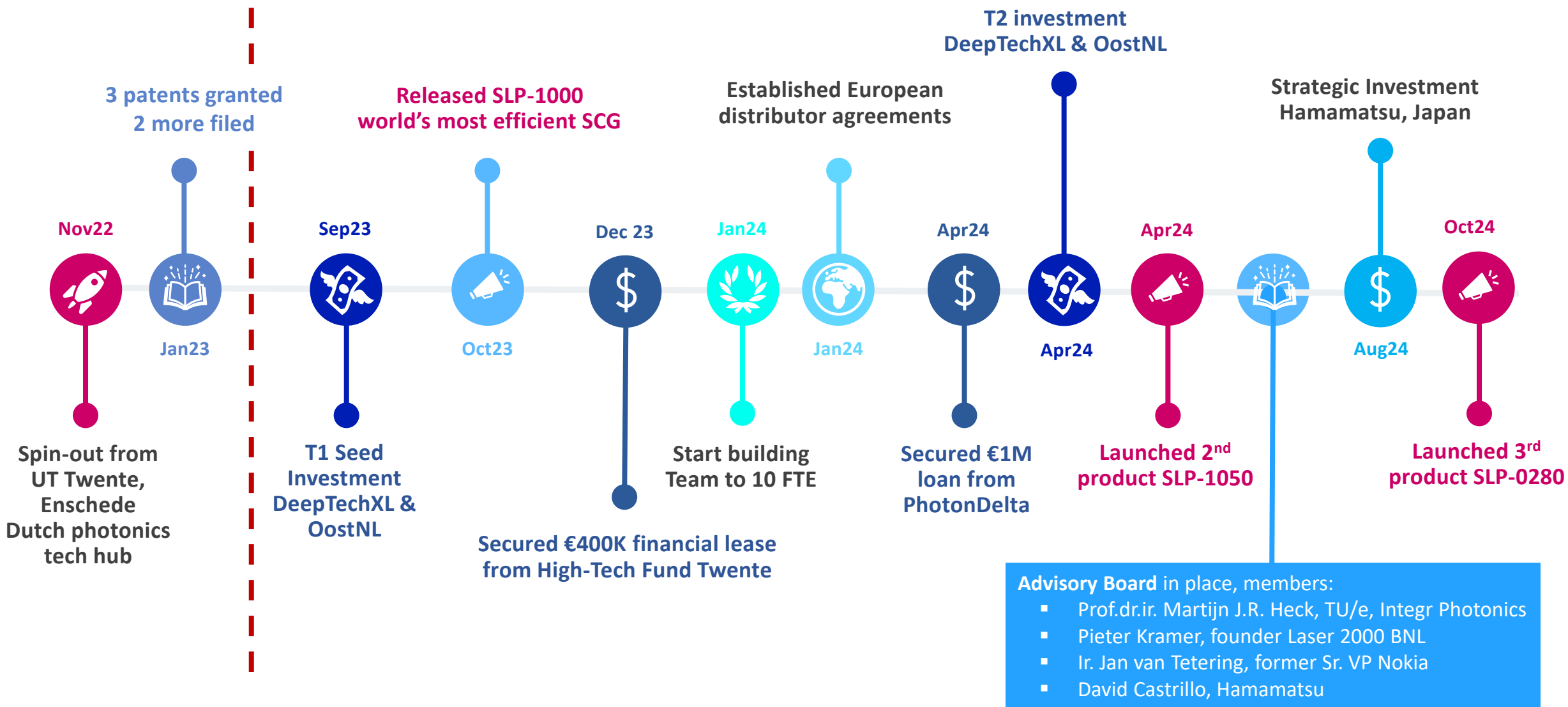

PAD TECHNOLOGY IN A NUTSHELL

Table 1. Efficiency comparison to previous state-of-the-art integrated SCG sources.

Technology	Materials	Pump Pulse Input		SCG 1/e Band width (nm)	Efficiency (nm/pJ)	Efficiency ratio of our work to cited work	
		FWHM (fs)	Energy (pJ)				
This work: s-pol. Optimized alternating waveguide	silicon nitride on oxide	190	34	950	28		
This work: p-pol. Optimized alternating waveguide	silicon nitride on oxide	190	9	375	42	s-pol. Optimized alternating waveguide	p-pol. Optimized alternating waveguide
two segment - either width or cladding removal - cascaded anomalous dispersion waveguide ²⁷	silicon nitride on oxide	60	220	83	0.4	74	110
uniform-width anomalous waveguide ²⁸	silicon nitride on oxide	115	590	150	0.3	110	160
wide (1300 nm) uniform-width anomalous waveguide ¹³	silicon nitride on oxide	120	1400	21	0.02	<u>1900</u>	<u>2800</u>

<https://doi.org/10.1002/adpr.202200296>

SLP

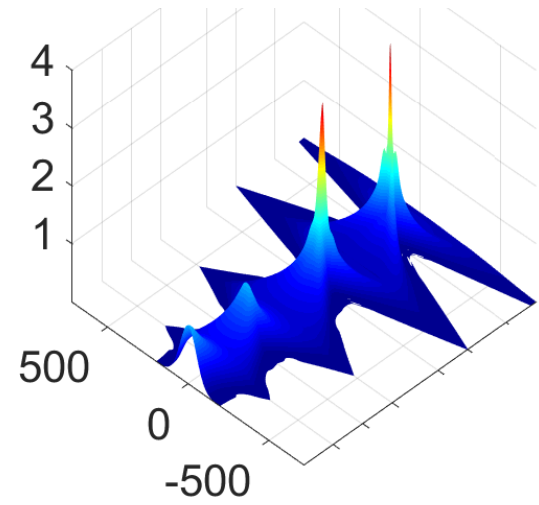
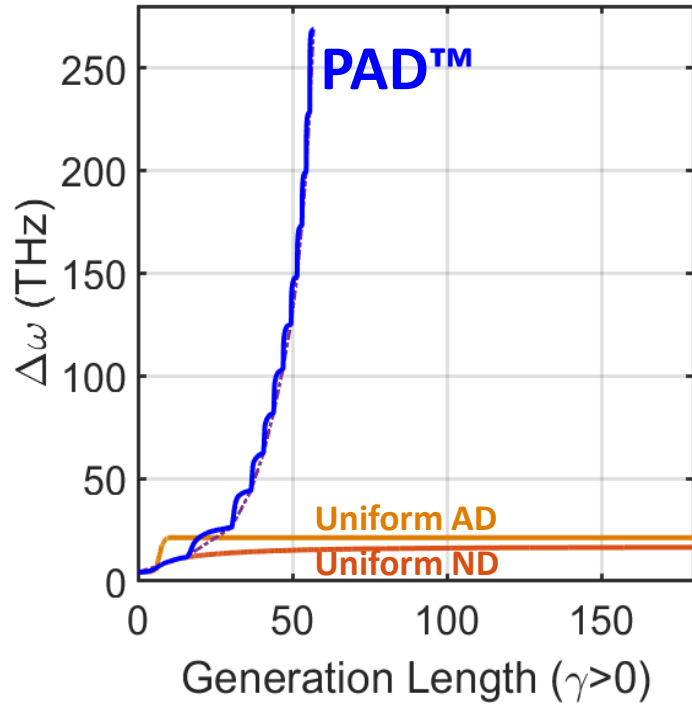

- ✓ Increased power efficiency
- ✓ Maximized bandwidth

- Alternating the sign of dispersion repeatedly:
 - Counters stagnation from normal dispersion SCG dynamics due to pulse broadening, peak power loss
 - Counters stagnation from anomalous dispersion SCG by disrupting soliton formation
- Nonlinear temporal compression of pulse with high quality

Another SCG technology being industrialized



We are **1900x** to **2800x** more efficient!

IN-HOUSE PRODUCT DESIGN

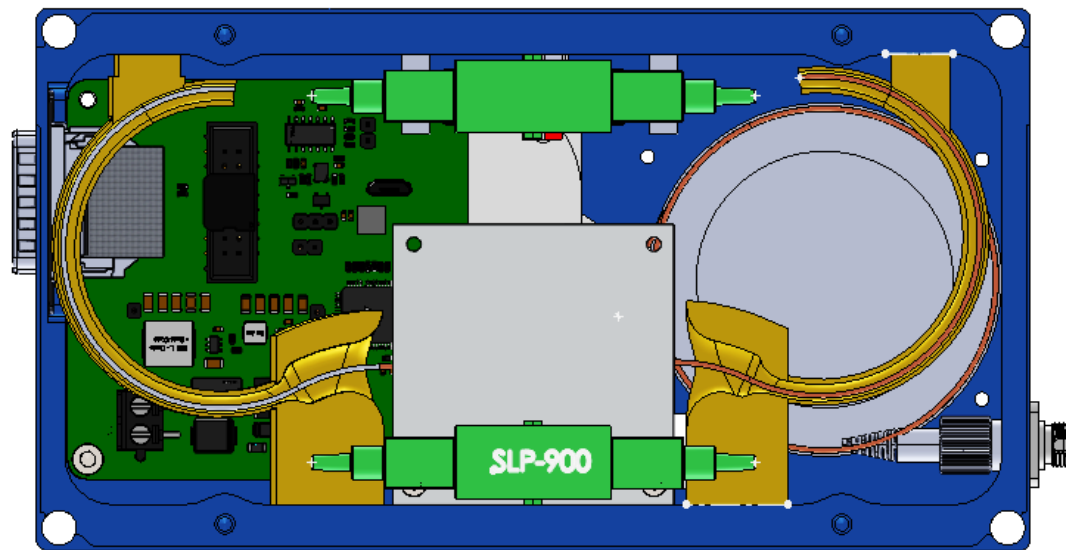

Optical subassembly integrated with control electronics and other fiber components

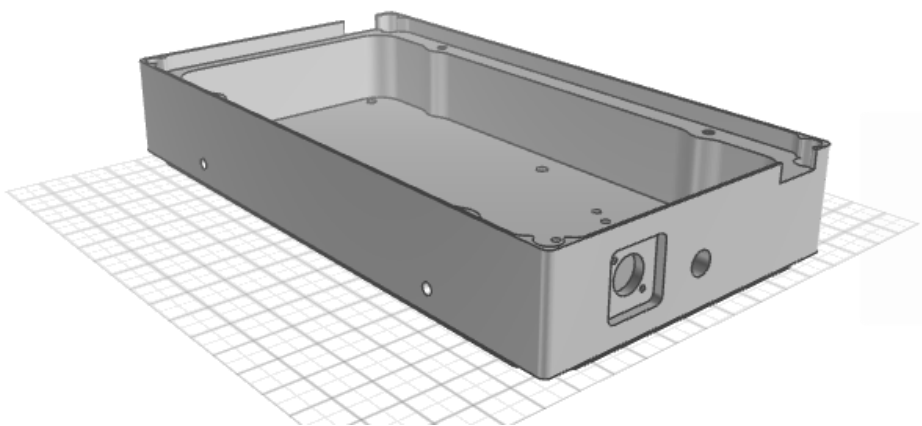

Fiber routing/support structures in housing (robustness)

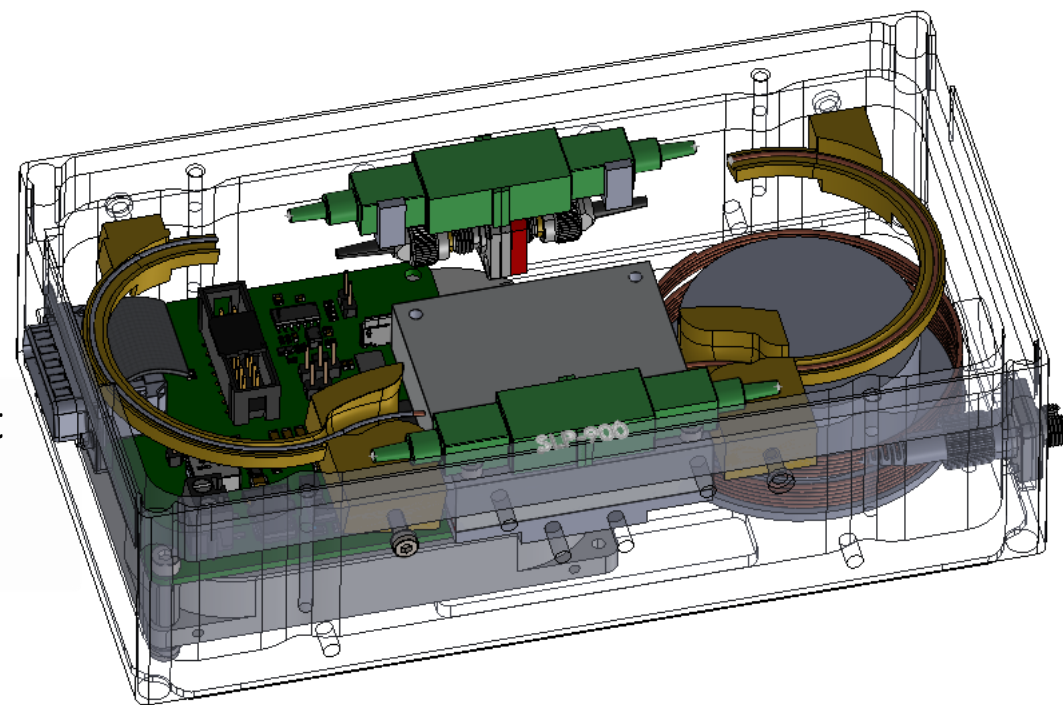

FABLESS PRODUCTION/PACKAGING + BESPOKE TEST



WINNING PRODUCT PORTFOLIO

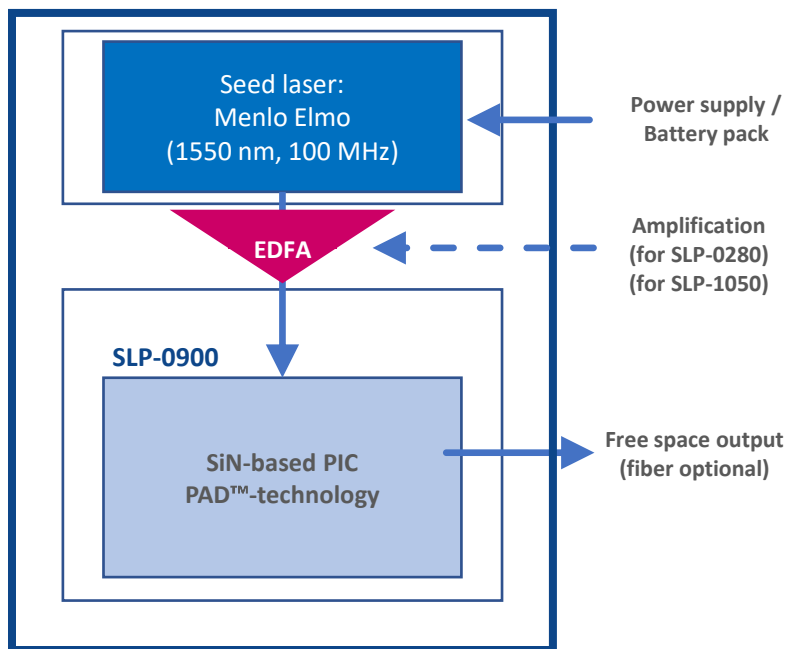

SLP-0280
SLP-1000
SLP-1050

	SLP-0280	SLP-1000	SLP-1050
Specs & USPs	Compact ultrafast pulse laser	Battery-operated wideband laser	Ultrawide bandwidth, low noise laser
Power	50 mW	3 mW	50 mW
3 dB Spectral bandwidth	400 nm	450 nm	860 nm
Pulse length	25 fs @ 100 MHz		
Amplitude stability	0.5 % RMS over 24 hr		
Spectral stability	-120 dB/Hz		
Size & weight	1 kg – 1 L		
Startup time	< 60 s		
Key Applications	Ultrafast Spectroscopy and Non-Linear Microscopy	Waveguide Characterization, Fiber Sensing	Optical Coherence Tomography, Hyperspectral Imaging

TEAM

Total Team

- 12 FTE - 13 employees
- Mgmt + Adm: 6 FTE
- Engineers: 5 FTE
- Level: 5 PhD, 6 Master



Haider Zia Founder & CTO

- Over 10 years optics & photonics research experience
- PhD at Max Planck Institute and MIT (2015)
- Postdoc & Senior researcher at Twente University (2022)
- Inventor of patented extremely power efficient wide-bandwidth chip integrated lasers
- NWO Demonstrator Grant Award top-place recipient



Elly Schietse CMO

- 30 years scale-up experience
- Long career in technology start-ups & scale-ups
- Track record marketing, marcom & PR
- International HR management
- Implemented & certified ISO 9001, 27001 & 14001
- Lean organizational design
- Experience in high-tech, ICT, SaaS, ERP, IoT, semiconductor, Industry 4.0



Bradley Snyder COO

- Over 20 years multi-disciplinary experience
- PhD at Tyndall National Institute, Ireland (2013)
- Track record in photonics packaging manufacturing
- Long experience in R&D, silicon photonics, optical design
- Spearheaded every stage of photonics design, layout, wafer-scale fabrication and test



Cees Links CEO

- Over 35 years industry experience
- Alumnus Twente University (1982)
- GM/VP (NCR Computers, AT&T, Lucent Technologies, Qorvo)
- Established Wi-Fi as worldwide standard
- Founder/CEO (GreenPeak Technologies) with successful exit to Qorvo (2016)
- RF-semiconductor industry, wireless data communication, ultra-low power



Jeroen Biesterbos CCO

- Over 10 years commercial experience
- ams-OSRAM and Sensata Technologies
- Track record of success in Business Development, Product Marketing, Product Management
- LiDAR semiconductor lasers and ecosystem
- Automotive & industrial background



Paul de Wit CFO

- Over 30 years experience in Finance
- Master in Finance & Control
- Experience in both corporates & start-up/ scale-up international environments
- Track record in equity rounds, exits, non-dilutive funding, subsidies and working capital funding at private equity backed semiconductor companies
- Experience with managing HR, real estate and office IT

ESG INITIATIVES AND IMPACT

ENVIRONMENTAL

- Energy efficiency
- Upstream supplier management
- Emergency preparedness
- Waste management
- Recycling process
- Employee travel

SOCIAL

- Diversity and inclusion
- Employee welfare and well being
- Performance & remuneration
- Health & safety
- Customer satisfaction
- Training & mentoring

GOVERNANCE

- Ethical standards
- Transparency & integrity
- Stakeholder engagement
- Advisory board
- Responsible supply chain
- Quality management \cong ISO9001
- Cybersecurity \cong ISO27001



ESG IMPACT

- Improved product quality and cost savings ... in particular in the medical world with wideband lasers for OCT
- Production efficiency and waste reduction
- Enabling technology for higher energy efficiency
- Accessibility to advanced technology
- Educational and research opportunities
- Enhanced competitiveness of customers & OEMs
- Employment in supply chain & photonics industry

Gender Diversity

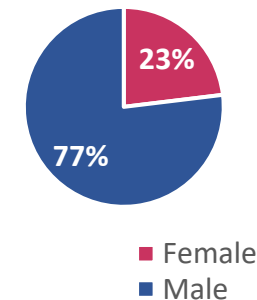

Age Diversity

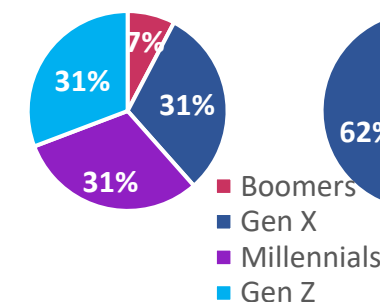

Cultural Diversity

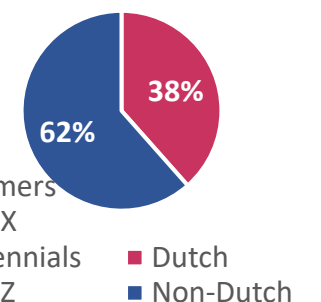

WHY YOU WANT TO JOIN OUR TEAM

- Start-ups are a great place to start working
 - Dynamic environment
 - Instant impact
 - Growth opportunities
- SuperLight Photonics is the best place to ignite your career
 - Exceptional team
 - Diversity in experience, gender & cultural background
 - Experienced management team
 - Complimentary skillsets & experience - mix of successful entrepreneurs and researchers
 - Quick growth, fast pace, never a dull day
 - Exciting career opportunities in line with our company growth and your ambition
 - Enschede photonics hotspot and global technology hub
- 9 Vacancies in the 2025 hiring plan
 - **Will you fill one of them?**
 - ⇒ Send in your resume now

A large, pink, speech bubble-shaped graphic pointing downwards and to the left. Inside the bubble, the text "Send your CV to HR" is written in a white, sans-serif font, followed by the email address "hr@superlightphotonics.com" in a larger, white, sans-serif font.

Send your CV to HR
hr@superlightphotonics.com

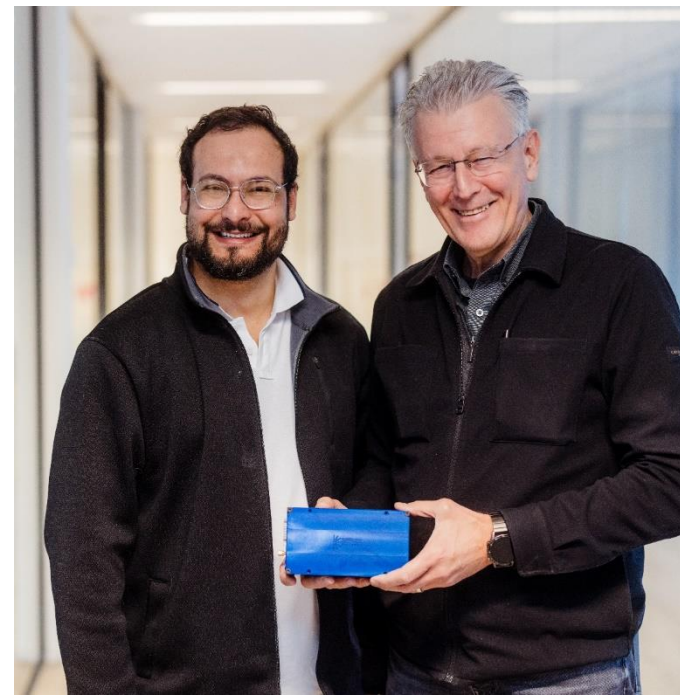

Better Light | More Insight

Thank you.



 [SuperLightPhotonics.com](https://www.SuperLightPhotonics.com)

 [LinkedIn SuperLight Photonics](#)